



PRODUCT SPECIFICATIONS

In-line type OZONE MONITOR

MODEL EG-610 series

Model: EG-610CV/SH (Vertical type control unit/SH type detector unit)

Model: EG-610CH/SH (Horizontal type control unit/SH type detector unit)

EBARA JITSUGYO CO., LTD.

1. General description

Ozone Monitors, Model EG-610 series (hereinafter referred to as “the monitor”), are inline-type ozone monitors equipped with a microprocessor. They have developed as a sensor for controlling ozone concentration of the semiconductor manufacturing process, and for controlling a high-concentration ozone generator for the same process.

It consists of a main body (control unit) and detector unit, and continuous measurement of ozone concentration can be performed only by connecting piping to both ends of the detector unit. With this monitor, it is possible to easily perform zero calibration with external signals or switches on the front panel. There is another built-in interval timer other than the purge timer*, and zero calibration can be performed periodically at arbitrarily set time intervals. The zero calibration value obtained at this time is stored even when the power is turned off, and the last zero calibration value is applied the next time the power is turned on. The self-diagnosis function monitors and displays the abnormality of inside of the monitor.

Since this monitor has a built-in temperature sensor inside the detector unit, temperature compensation of concentration (gas temperature compensation) can be performed. Similarly, since the pressure sensor is built in the detector unit, gas pressure can be automatically compensated to atmospheric pressure. With using the optional serial port, you can obtain more accurate digital data by data communication with the host computer.

* “purge time”: the replacement time of zero gas and sample gas

2. Measuring principle

This monitor is an UV absorption type ozone monitor, which can detect the quantity of absorption of UV rays by ozone in the sample gas introduced into the detector unit and measure the ozone concentration.

A low-pressure mercury lamp (emission wavelength 253.7 nm) is used for the light source. As the quantum of light absorbed by ozone existing within the optical path ‘T’ obeys the Lambert-Beer’s Law, concentration of ozone can be measured as follows.

$$C = \frac{A}{\alpha T} \times \log \left(\frac{I_0}{I_x} \right) \times \frac{273 + t}{273} \times \frac{P_0}{P + P_0}$$

where: C= Concentration of ozone
 A= Constant
 α = Absorption coefficient of ozone
 T= Optical path length (Cell gap)
 I₀= Incident UV light intensity
 I_x= Transmitted UV light intensity
 t= Gas temperature
 P₀= Atmospheric pressure
 P= Gas pressure (Gauge)

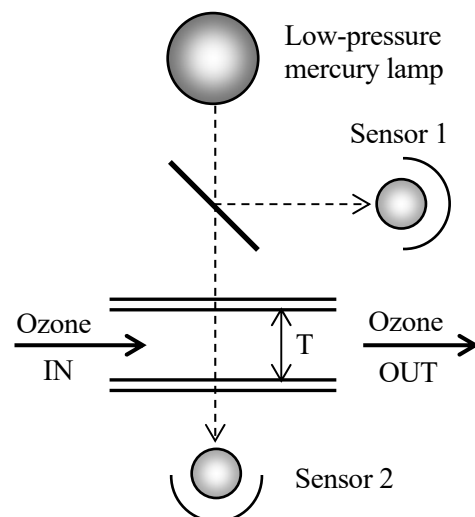

Figure-1 Logic diagram

3. Specifications

3.1 Standard specifications

Model	EG-610CV/SH (Vertical type control unit/SH type detector unit) or EG-610CH/SH (Horizontal type control unit/SH type detector unit)
Measuring principle	UV absorption method
Detection target	Ozone gas (without impurities)
Measuring range	Select one from the following measuring range below when ordering. Please consult us for concentrations other than the below. 0–10.0 g/m ³ (N), 0–20.0 g/m ³ (N), 0–30.0 g/m ³ (N), 0–40.0 g/m ³ (N), 0–50.0 g/m ³ (N), 0–100 g/m ³ (N), 0–200 g/m ³ (N), 0–300 g/m ³ (N), 0–400 g/m ³ (N), 0–500 g/m ³ (N), 0–1000 g/m ³ (N), 0–2000 g/m ³ (N), 0–3000 g/m ³ (N), 0–10.0 wt%, 0–20.0 wt% <u>Note</u> <ul style="list-style-type: none"> • For 0–500 g/m³(N) and 0–1000 g/m³(N), there is no pressure compensation. • Concentration range of 2000 g/m³(N) or higher is for optional reduced pressure compensation. • The unit of wt% is based on oxygen raw material.
Measuring interval	Continuous measurement
Sampling method	Pressurized air supplying method or external suction pump sampling method <u>Note</u> External pump is necessary to be prepared by user side.
Measuring flow rate	0.5–20.0 L/min <u>Note</u> Even at flow rates less than 0.5 L/min, measurements can be made, but the response may be delayed or the concentration may be lowered due to ozone decomposition.
Span drift	Within ±1% FS/month
Zero drift	Within ±1% FS/month <u>Note</u> <ul style="list-style-type: none"> • Perform zero calibration with the light intensity stabilized after the power is turning on, and after that, perform zero calibration at least once a day. • Perform zero calibration with the raw material gas (zero gas) flowing before supplying ozone gas and under the same pressure conditions as when measuring the ozone concentration.
Linearity	Within ±1% FS <u>Note</u> It is the case of pressurization of 0.3 MPa (G) and the measuring range is 250 g/m ³ (N) or less. (1000 g/m ³ or less in concentration without pressure compensation)

Repeatability	1% FS or less
Display	<p>(1) Main display Concentration (The minimum display digit depends on measuring range.)</p> <ul style="list-style-type: none"> • Measuring range of 10 or more and less than 100: Displays from down to 1 decimal place • Measuring range of 100 or more: first place of integer (no decimal point) <p>(2) Sub display Temperature unit: °C Pressure unit: MPa (G)</p>
Analog output	0–1 V DC or 0–10 V DC (factory default setting) The load resistance connectable externally is 10 kΩ or more.
Monitor input	Zero calibration start pulse input, photocoupler LED driven (Current $i = 10\text{--}20$ mA)
Monitor output	<p>4 types of the following digital outputs. Photocoupler open collector output Applied voltage (V_{cc}): 50 V DC or less, Current (i): 1–10 mA</p> <ul style="list-style-type: none"> • Measurement signal: Turns on only when the measurement is progressing normally • Monitor error signal: Turns on when an abnormal condition occurring • Concentration alarm (2 systems): Any single-level alarm setting is available, it turns on when exceeding the set value. • Pressure alarm (2 systems): Any single-level alarm setting is available, it turns on when exceeding the set value.
Detector unit control output	<p>Semiconductor relay contact output, all a-contact signal Contact capacity: 100 V AC/DC, 0.4 A (peak value) or less</p> <ul style="list-style-type: none"> • Pump control signal: Turns on in synchronization with the monitor power supply. • Solenoid valve control signal: Turns on when sample gas is being purged.
Self-diagnosis function	Light source abnormalities, cell contamination, and internal circuit abnormalities are detected and displayed.
Test mode	Each test for analog output, solenoid valve operation, concentration alarm signal output, and error signal output are available.
Function of compensating the concentration	<p>(1) Temperature compensation Compensation range: 0–45°C Compensated temperature: 0°C</p> <p>(2) Pressure compensation Compensation range: 0–0.3 MPa (G) (Gauge pressure sensor equipped) Compensated pressure: Atmospheric pressure 1013 hPa (abs) Pressure alarm setting (Any single-level alarm setting, 2 systems) is available.</p> <p><u>Note</u></p> <ul style="list-style-type: none"> • The above is the factory default setting. Temperature compensation can be canceled by the customer. • Optional pressure sensor other than the gauge pressure sensor can also be selected. <p>☞ See “3.2 Optional Specification” for details.</p>
Zero calibration	By manual zero or auto-zero function

Span adjustment	Digital setting (in an increment of 0.1%)
Power Supply	100–240 V AC \pm 10%, 50/60 Hz (Class D grounding required)
Power consumption	25 VA
Outside dimensions	Vertical type control unit (EG-610CV): 72W \times 200H \times 200D mm Horizontal type control unit (EG-610CH): 200W \times 72H \times 200D mm Detector unit (EG-610SH): 110W \times 160H \times 90D mm <u>Note</u> Protruding parts and legs are not included in these dimensions. ☞ See “See attached drawing.”
Panel cutout	Vertical type control unit (EG-610CV): 66W \times 180H mm Horizontal type control unit (EG-610CH): 180W \times 66H mm Panel thickness: 2–5 mm
Mass	Control unit: Approx. 1.6kg Detector unit: Approx. 1.6kg
Piping connections	VCR fitting equivalent for O.D. 1/4 inch tube
Distance between inlet fitting and outlet fitting	129.4 +0, –2 mm
Materials of wetted parts	SUS316L, Synthetic quartz, Perfluoroelastomer
Pressure range	Normal pressure: 0 MPa (G) or more, 0.3 MPa (G) or less Maximum pressure: 0.6 MPa (G) or less <u>Note</u> <ul style="list-style-type: none"> • The above pressure range is when the standard specification gauge pressure sensor is installed or when no pressure sensor is specified at the time of ordering. If another pressure sensor is selected as an option, please refer to “3.2 Optional specification”. • Using it beyond the maximum pressure may cause a malfunction. • If a gauge pressure sensor is installed, an error may be detected when the pressure becomes negative.
Operating environment	Temperature: 5–40°C, humidity: 90% RH or less (no condensation)
Sample gas temperature	5–40°C
Installation environment	Places with altitude 2000 m or less
Accessories	Interface cable: 1.5 m, 1 set Fuse: 250 V AC, T 1 A, 1 pc (UL compliant, Time lag type) <u>Note</u> <ul style="list-style-type: none"> • The product is adjusted for a cable length of 1.5 m at the time of shipment. If you wish to change the cable length, please be sure to request the monitor to be readjusted. • You can select cable length other than standard optionally. ☞ See “3.2 Optional specification” for details.

3.2 Optional specifications

Pressure compensation	In addition to the standard specifications, the following two types of pressure sensors can be selected. The compensated pressures are both at atmospheric pressure [1013 hPa (abs)].
-----------------------	---

Table-1 Optional pressure sensor

Pressure sensor	Normal pressure (Compensation range) [hPa (abs)]	Maximum pressure [hPa (abs)]
Absolute pressure sensor	500–1961	3922 or less
Reduced pressure sensor	10–343	1470 or less

Note

- The minimum pressure is 10 hPa(abs). If the pressure becomes lower than this, an error may be detected.
- Please note that pressure below the compensation range will increase the error in concentration measurement.
- If you select these pressure sensors, the pressure display unit is hPa (abs).
- When the reduced pressure sensor is selected, we calibrate the concentration under atmospheric pressure (without pressure compensation) at our factory.

Analog current output	4–20 mA DC (Insulation output) The load resistance connectable externally is 750 Ω or less.
Serial port	Data transfer by RS232C Communication speed: 9,600bps Communication method: Full duplex Data bit length: 8 bits Stop bit length: 1 bit Parity: None X Parameter: Not used
Interface cable	Cable length: 3, 5, 10, 15 m The connection cable between the control unit and the detection unit is 1.5 m as standard, but it can be extended up to 15 m. <u>Note</u> <ul style="list-style-type: none"> • The monitor has adjusted according to your specified cable length at the time of shipment. When changing cable length, be sure to request us to readjust the monitor. • For maintaining performance, be sure to use genuine cables, and do not use cables exceeding 15 m.
DC power supply specifications	Power supply voltage: 24 V DC ± 4 V, power consumption 20 W or less

4. Description of function/operation modes

4.1 Standard Function

This monitor has the following functions.

4.1.1 Zero calibration

In the case of UV absorption type ozone monitor, the zero point may shift due to environmental conditions during measurement, or over the years of use.

In the monitor, the zero calibration can be performed with the switch operation on the front panel, or an external signal input (zero calibration start pulse input and zero set command), or a built-in timer. The calibrated value obtained at this time is stored even when the power is turned off, and this value will be used the next time the power is turned on.

Note

- The zero point may shift if you left the monitor without turning on the power for a long time. Be sure to perform the zero calibration with the light intensity of the low-pressure mercury lamp stabilized.
- Be sure to perform zero calibration with zero gas flowing. If zero calibration is performed while the sample gas is flowing, normal concentration value cannot be measured.
- Please use material gas or ozone-free gas as zero gas. When performing zero calibration, if you want to use zero gas separately instead of stopping the ozone generator and flowing the material gas, switch between the sample gas and zero gas using a three-way solenoid valve as shown in Figure-2.
- When using an external solenoid valve, please pay attention to the operating pressure. The maximum applied pressure is determined by the withstand pressure specification of the solenoid valve. Relay contact specifications for solenoid valve driving output from the terminal block of the detection unit are as follows:

contact capacity: 100 V AC (DC is also available), 0.4 A(peak value) or less, a-contact.

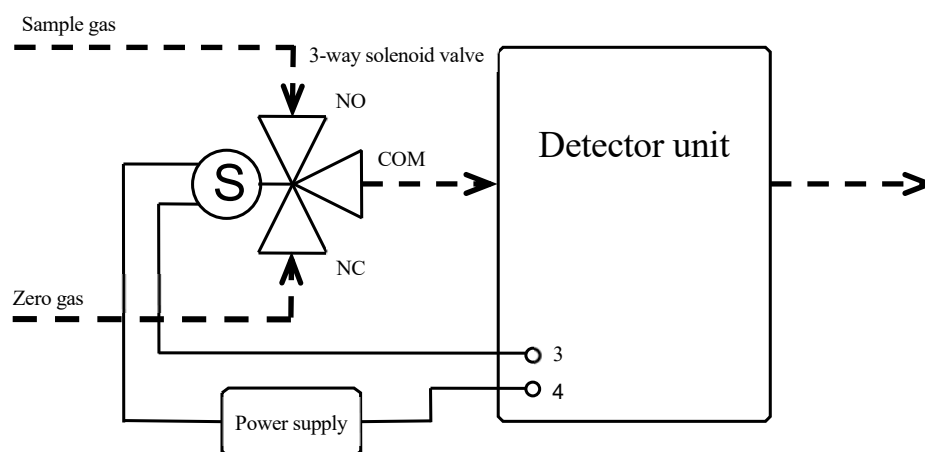

Figure-2 How to switch between Sample gas and Zero gas

Zero calibration is executed in the Measurement mode. You can select the manual zero calibration mode or auto-zero calibration mode described below. During zero calibration, the state immediately before zero calibration is held for each output: analog, concentration alarm 1 signal, concentration alarm 2 signal, pressure alarm 1 signal, pressure alarm 2 signal, and error signal.

(1) Manual zero calibration

■ Performing zero calibration

After setting “0” in the interval timer setting (INT), execute zero calibration in the cases of (a) to (c). Manual zero calibration will not be performed if a value is set other than “0”.

- When SW1 and SW2 on the front panel is pressed simultaneously for 1 second or more.
- When a pulse is input for 1 second or more to the zero calibration start pulse input (ZIN) of the signal terminal block.
- When the zero set command is input from the serial port (option).

When connecting to the zero calibration start pulse input of the signal terminal block of the control unit, limit the current to be allowed to 10 to 20 mA. The “ON” time of the controller, such as the sequencer or timer relay, should be 1 second or more.

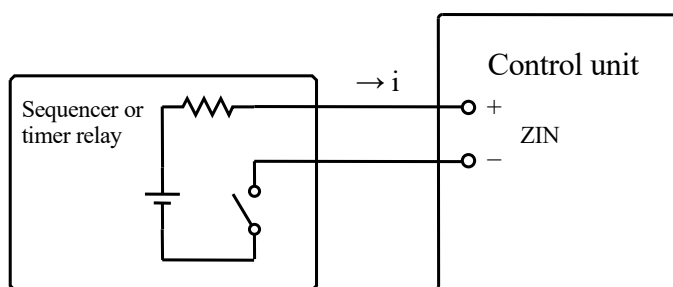

Figure-3 External signal connection example 1

If the output of the controller such as the sequencer is a transistor (open collector), please connect as shown in Figure-4. Take care of the polarity.

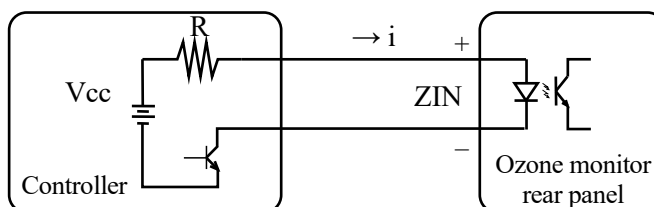

Figure-4 External signal connection example 2

To execute manual zero calibration, it is necessary to set the purge time value. Set it as follows.

■ Setting of purge time (time to replace sample gas to zero gas)

After checking the replacing time of the zero gas and the sample gas, set the purge time (P) in the range of 0 to 90 seconds (in increment of 10 seconds).

Solenoid valve control signal will be turned ON of the terminal block of the detector unit during sample gas purging. If the purge time is set to “0”, the solenoid valve is not switched and zero calibration will be performed immediately.

When the purge time is set to “P”, the zero calibration time will be “2P”*. While executing zero calibration (2P), the Status indicator blinks. (See Figure-5)

* Zero calibration time (2P) = sample gas purge time + zero gas purge time

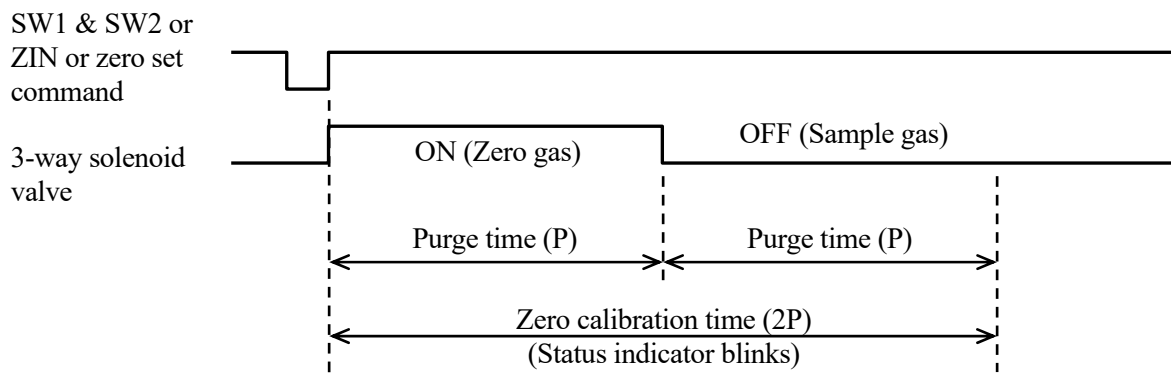

Figure-5 Timing chart of manual zero calibration

■ Stored zero calibration value

The zero calibration value acquired in manual zero calibration mode is stored in the nonvolatile memory at the same time as acquisition, and this value is applied the next time the power is turned on. However, if you leave the monitor without turning on the power for a long time, the zero point may shift. In such a case, be sure to perform zero calibration again.

(2) Auto-zero calibration

■ Performing zero calibration

Zero calibration is executed in the case of (a) to (c) below.

The first zero calibration is performed according to (a) or (b), and after that, continuous zero calibration is performed at intervals of the interval timer set value according to (c).

- (a) When the power is turned on in Measurement mode (after warm-up operation is completed).
- (b) When switching from other mode to Measurement mode by MODE switch.
- (c) When the interval timer set value or more has elapsed since the last zero calibration start.

In order to execute auto-zero calibration, it is necessary to set the values of interval timer and the purge time.

■ Setting of purge time (time to replace sample gas to zero gas)

Set the purge time for replacing the zero gas and the sample gas in the cell in the same way as in manual zero calibration.

■ Setting of Interval timer (executing cycle of zero calibration)

It can be set within the range of 30 seconds to 30 days by the interval timer. The alphabet displayed at the left end of the Main display shows time unit and the number on the right side shows setting time. (See Table-2)

Table-2 Setting time of Interval timer

Alphabet (left end)	Setting time	Time unit
None	(0), 30, 120, 300, 600	second
H	1, 2, 5, 10	hour
L	1, 2, 5, 7, 14, 30	day

Note

- Set the interval timer setting to a value other than “0”. When set it to “0”, manual zero calibration will be performed.
- An error will occur if the following conditions are not satisfied.

$$\boxed{[\text{Set value of purge time} \times 2] < [\text{Set value of interval timer}]}$$

When the purge time is set to “P” and the interval timer is set to “I”, the zero calibration time will be “2P” and it is executed automatically at the interval of “I”. (See Figure-6)

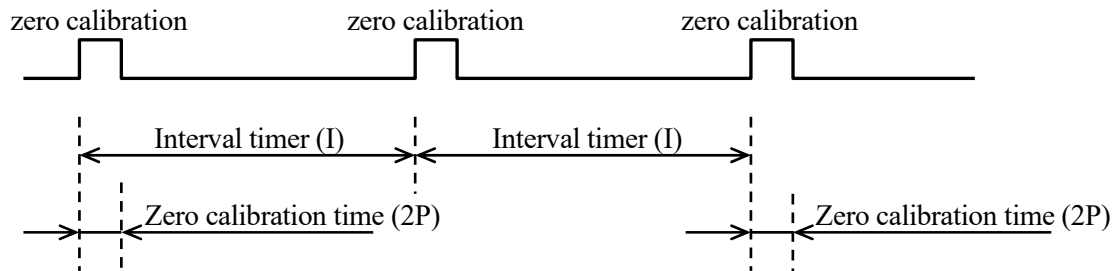

Figure-6 Timing chart of auto-zero calibration

■ **Stored zero calibration value**

The zero calibration value acquired in auto-zero calibration mode is stored in nonvolatile memory when 1 hour or more has passed since the last zero calibration value was stored, and this value is applied the next time the power is turned on. However, if you leave the monitor without turning on the power for a long time, the zero point may shift. In such a case, be sure to perform zero calibration again.

4.1.2 Analog voltage output

A voltage value proportional to the concentration value is output to the analog voltage output. The output voltage range of this monitor is either “DC 0 to 1 V” or “DC 0 to 10 V” and was set when shipping. When the concentration value exceeds the full scale, the voltage value at full scale will be output. The load resistance connectable externally is 10 kΩ or more.

4.1.3 Concentration alarm (Photocoupler output)

The monitor has two systems of concentration alarm. When the concentration value exceeds the alarm set value during measurement, the concentration alarm signal output connected to the signal terminal block of the rear panel of the control unit will be turned ON. This alarm set value is settable from “0” to the full scale value.

If the concentration alarm value is set to “0” (concentration alarm function is disabled), the concentration alarm signal output will not turn ON regardless of the concentration value. These two systems of concentration alarm signal output operate independently, and can set, for example, maximum and minimum two values.

4.1.4 Self-diagnosis function

If any abnormality is detected during measurement, E□□× (× is an error number, □ means blank.) is displayed on the Main display of the front panel, and at the same time, the error signal output of the signal terminal block turns ON.

When an error message is displayed, the measurement is not progressing normally. The error signal continuously output unless the error is canceled. When an error occurs, the signal output during measurement turns OFF, and the analog output, concentration alarm output, and pressure alarm output are held in the state just before detecting the error.

4.1.5 Gas temperature compensation

Since the measured value is inversely proportional to the gas temperature, it is compensated automatically using the signal from the temperature sensor to eliminate the influence. ON/OFF (enable/disable) operation is settable by the COMPENSATION switch on the front panel.

The effective compensation range is as described follows. However, even if the temperature exceeds the compensation range, the temperature will be compensated as a service range, but the measurement accuracy will not be guaranteed.

Gas temperature compensation range: 0–45°C

Compensated temperature: 0°C (273 K)

Compensated ozone concentration

$$= \text{Uncompensated ozone concentration} \times \frac{\text{Gas temperature} + 273}{273}$$

4.1.6 Pressure compensation

As this monitor can measure supplied ozone gas, pressure may be applied to the detector unit. Since the concentration value is proportional to the pressure, in order to eliminate the influence, the atmospheric pressure conversion is automatically performed using the signal from the pressure sensor. ON/OFF (enable/disable) operation is settable by the COMPENSATION switch on the front panel.

A gauge pressure sensor is equipped as standard specification and it compensates the ozone concentration under pressure. The compensated pressure is 1 atm (atmospheric pressure). The pressure value is displayed on the sub display.

Pressure compensation range: 0–0.3 Mpa (G)

Maximum pressure: 0.6 Mpa (G) or less

Pressure value unit: Mpa (G)

Compensated ozone concentration

$$= \text{Uncompensated ozone concentration} \times \frac{\text{atm}}{\text{Gas pressure (abs)}}$$

However, even if the pressure exceeds the compensation range, the pressure will be compensated as a service range, but the measurement accuracy will not be guaranteed. Be careful if exceeding the maximum pressure, it may cause failure of the pressure sensor.

4.1.7 Pressure alarm (Photocoupler output)

The monitor has two pressure alarms. When the pressure value exceeds the alarm set value during measurement, the alarm signal output connected to the signal terminal block of the rear panel of the control unit will be turned ON. Pressure alarm 1 setting controls pressure alarm 1 signal output and pressure alarm 2 setting controls pressure alarm 2 signal output respectively.

If the pressure alarm value is set to “0” (pressure alarm function is disabled), the pressure alarm signal output will not turn ON regardless of the pressure value. These two pressure alarm signal outputs operate independently of each other, for example, you can set binary values of maximum and minimum values. The pressure alarm settable range is 0.001 to 0.588 MPa (G).

4.2 Optional Function

The following functions are optional. They are not available in the standard specification.

4.2.1 Pressure compensation and pressure alarm

In addition to the standard gauge pressure sensor compensation, two types of pressure sensors shown in the table below can be selected when ordering. The display units of pressure values are hPa (abs), and the effective compensation ranges are as shown in Table-3. The compensated pressure is 1 atm (atmospheric pressure). As with standard specifications, even if the pressure exceeds the range in the table, the pressure will be compensated as a service range, but the measurement accuracy will not be guaranteed. Also, pressure alarm can be set similar to standard specifications.

Table-3 Optional pressure sensor, compensation range, setting range of pressure alarm

Type	Pressure compensation range [hPa (abs)]	Maximum pressure [hPa (abs)]	Pressure alarm setting range [hPa (abs)]
Absolute pressure sensor	500–1961	3922 or less ^{*1}	1–3922 ^{*2}
Reduced pressure sensor ^{*3}	10–343	1470 or less ^{*1}	1–343 ^{*2}

*1 Be careful if exceeding the maximum pressure, it may cause failure of the pressure sensor.

*2 If the pressure alarm value is set to “0”, the pressure alarm signal output will turn OFF, regardless of the pressure value.

*3 If you select a reduced pressure sensor, it will perform concentration calibration at atmospheric pressure.

4.2.2 Analog current output

A current value proportional to the concentration value is output to the analog current output. When the concentration value exceeds the full scale, the full scale value (20 mA) will be output.

The analog current output of the monitor is isolated 4 to 20 mA DC and is output from the signal terminal block IO of the rear panel of the control unit. The load resistance connectable externally is 750 Ω or less.

4.2.3 Serial port

This is RS232C compliant serial port. Data is transferred and received by handshaking with the host computer (external control device).

If there is no directive command to execute from the host computer, the monitor will not output data. Also, the monitor will not respond even if it receives commands other than the specified (4 types) commands.

For connection to the host computer, use a commercially available straight cable (9 pin D-Sub).

Note

Size of the set screw for fixing this connector is UNC #4-40 (inch screw).

4.2.4 DC power supply

In place of the standard specification AC power supply unit, it can be replaced with a 24 ± 4 V DC 20 W power supply unit. In this case, the enclosure will be at GND potential.

4.3 Operation mode

4.3.1 Measurement mode

These are modes for measuring ozone concentration and consist of the following three types.

(1) Warm-up operation

Warm-up operation is automatically performed for 20 minutes when the power is turned on in the Measurement mode. During the warm-up operation, the remaining time is displayed on the Main display.

(2) Ozone concentration measurement

When the warm-up operation is completed, ozone concentration measurement is automatically started. The measurement signal output will turn ON, and the ozone concentration will be displayed on the Main display. At the same time, analog output proportional to the concentration is output from the signal terminal block of the control unit.

(3) Zero calibration

There are two modes that can perform zero calibration in the Measurement mode: Manual zero calibration, Auto-zero calibration.

4.3.2 Check mode

This mode is used for checking the light intensity of the sensor 1 and sensor 2.

4.3.3 Set mode

There are 7 types of standard settable data: concentration alarm set value (2 systems), pressure alarm set value (2 systems), interval timer set value, purge time set value, and span calibration ratio.

Each set value is stored in nonvolatile memory and is held internally even when the power is turned off.

4.3.4 Test mode

This is the mode for testing the external signal connected to this monitor and can perform the following three kinds of tests.

(1) Test mode 1 (analog output test)

The analog output can be changed from 0% → 25% → 50% → 75% → 100%, and the value obtained by multiplying the full scale value by the displayed ratio will be output.

(2) Test mode 2**(a) Solenoid valve test**

ON/OFF switching operation can be tested while a solenoid valve is connected externally.

(b) Error signal output test

This is used for checking the error signal output when an error is detected.

(3) Test mode 3 (Concentration alarm signal output test)

Alarm signal output can be tested when the concentration exceeding the alarm set value is detected.

5. Replacement parts list

Table-4 shows the replacement parts for this unit. The warranty period is 12 months from the date of delivery

Table-4 Replacement parts

Parts name	Goods code	Quantity/unit	Recommended replacement cycle	Remarks
Regular replacement parts (the consumables)				
Low-pressure mercury lamp	BZ103_□ ^{*1}	1 pc	Approx. 2 years	The Low-pressure mercury lamp has an operating life so that the light intensity may decrease or it may not emit light.
Other replacement parts				
Sample cell ^{*2, *3}	—	1 pc	—	Replace it when deteriorated due to erosion, contamination, cloudiness, and corrosion.
Seal material for cell ^{*2, *3}	—	1 set	2–4 years	O-rings made of perfluoroelastomer are used. Due to deterioration, the sealability will deteriorate. Replacement is required for maintenance.
UV sensor/ Substrates ^{*3}	—	—	Approx. 5 years	Deterioration depends on its used conditions.
Fuse	EF010_□ ^{*1}	1 pc	—	O.D. 5.2 × 20, 250 V AC, T 1 A, UL compliant
Cell block ^{*3}	—	1 pc	—	Deterioration depends on its used conditions.
Pressure sensor ^{*3}	—	1 pc	—	Deterioration depends on its used conditions.

*1 Identification number for our company (e.g., A, B, C ...) is described in “_□” at the end of the Goods code. When you order replacement parts, please inform us of the 5-digit Goods code starting with the alphabet (e.g., BZ123).

*2 The degree of deterioration varies depending on the sample gas concentration and usage conditions. If the sample gas contains materials, such as hydrogen fluoride and moisture, the wetted parts of the monitor may be eroded, contaminated, clouded or corroded.

Note that if the ozone monitor malfunctions or becomes unmeasurable due to a substance other than ozone, it will not be covered under the warranty even if it is in the warranty period.

*3 Since replacement should be done in our factory, contact us if necessary.

6. Installation

This monitor is precision equipment. Avoid places that may affect the monitor, and install it so that it can be easily inspected and removed.

6.1 Installation conditions

To prevent damage or failure of the monitor and ensure stable operation and safety, install the monitor avoiding the following places.

- Dusty place, salt damage district or any place where corrosive gases such as hydrogen sulfide gas, sulfurous gas, or halogen gas is floating in the atmosphere.
- High-temperature and high-humidity atmosphere and a place subject to significant temperature change.
- A place subject to strong or continuous vibration.
- A place subject to direct sunlight.
 - * Please consider installation environment when installing outdoors.
- A place near strong magnetic field, electric field, and radiofrequency emission source.
- A place where sufficient maintenance/inspection space cannot be ensured.
- A place where an explosive gas may be generated.
- A place where rain directly affects the product.
- A place at an altitude exceeding 2000 m.
- Place where the rated contamination degree of 2* may exceeded in opening/closing of the monitor body cover.

* Contamination degree of 2

The inside of the monitor is made assuming only when non-conductive pollution occurs. Including the possibility of temporary conduction caused by condensation, it corresponds to general environment (e.g., office environment).

6.2 Power supply

Concerning the power supply for the monitor, use of the power supply for instrumentation is recommended. In addition, check the supply voltage and power cable specifications (rating) before use. If an inductive load or a large capacity load is connected to the power line, it may interfere with the measurement. Be sure to take measures to prevent surges from occurring.

Appropriate tightening torque for the terminal block is 1.4 N·m. Be sure to ground for safety.

Note

A power supply cable is not included.

6.3 Installation of detector unit

Install the detector unit taking care of the following items.

- The front side and the top side are used for the maintenance.
A space that allows inspection and operation is necessary on the top side. The low-pressure mercury lamp is fixed in the back side.
- Provide a space for using a screwdriver on the top side and the left and right of the detector unit.
- Piping so that no load is applied to the fittings.
- Since the light emission of the internal low-pressure mercury lamp may become unstable, do not install it other than the direction shown in Figure-7 (piping direction should be horizontal).

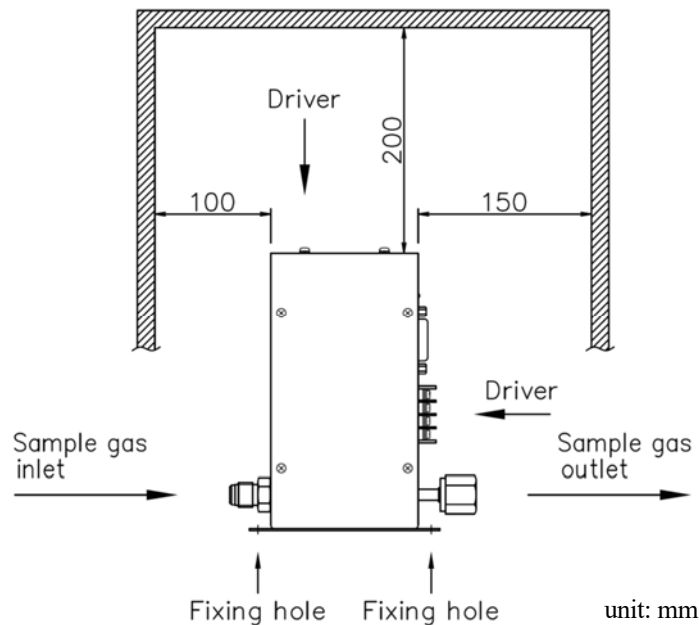
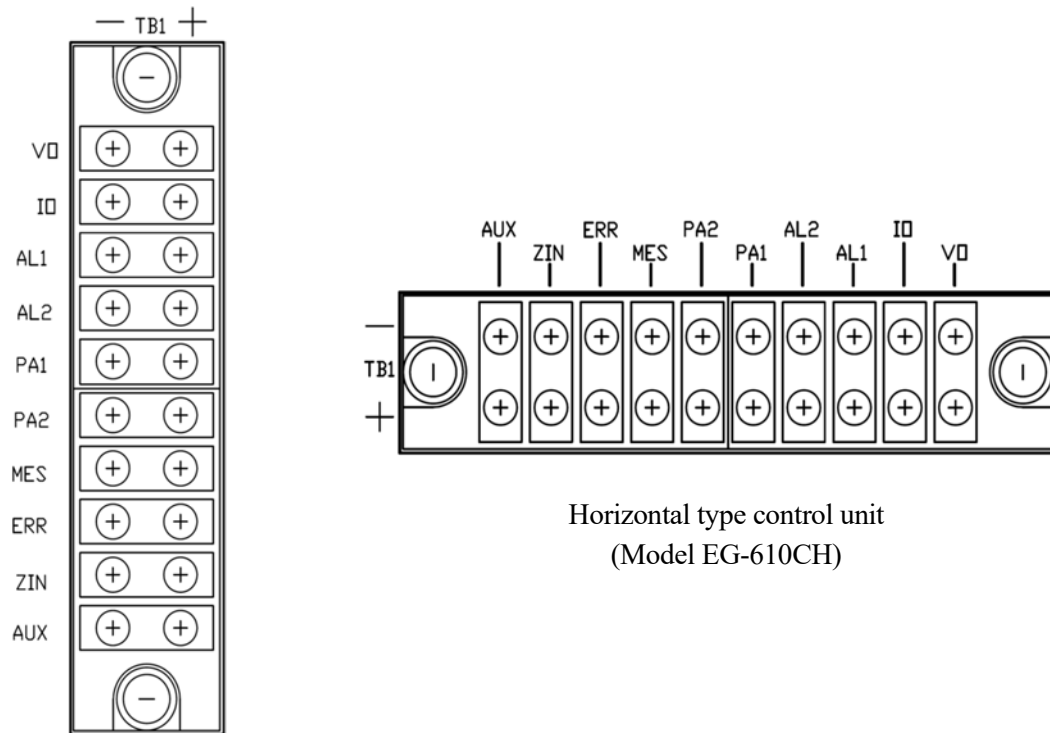

Figure-7 Installation condition

6.4 How to connect external signals

6.4.1 Signal terminal block (control unit)

Connect input/output signals here. These are input/output signals from the signal terminal block on the rear panel of the control unit. In the vertical type control unit, the right side of the terminal block is the positive side, while in the horizontal type control unit the bottom side is the positive side. Incorrect polarity may cause failure, so connect it carefully. Suitable solderless terminals are for M3. Appropriate tightening torque is 0.5 N·m.



Vertical type control unit
(Model EG-610CV)

Horizontal type control unit
(Model EG-610CH)

Figure-8 Signal terminal block

- VO:** Analog voltage output
0–1 V DC or 0–10 V DC (factory default setting)
The load resistance connectable externally is 10 k Ω or more.
- IO:** Analog current output [option]
4–20 mA DC
The load resistance connectable externally is 750 Ω or less.
- AL1:** Concentration alarm 1 (Photocoupler output)
This turns ON when the concentration value exceeds the concentration alarm 1 set value.
- AL2:** Concentration alarm 2 (Photocoupler output)
This turns ON when the concentration value exceeds the concentration alarm 2 set value.
- PA1:** Pressure alarm 1 (Photocoupler output)
This turns ON when the pressure value exceeds the pressure alarm 1 set value.
- PA2:** Pressure alarm 2 (Photocoupler output)
This turns ON when the pressure value exceeds the pressure alarm 2 set value.
- MES:** Measurement signal (Photocoupler output)
When it is measuring normally, it becomes ON, when abnormality occurs in the monitor, or switching to other than Measurement mode turns OFF.
- ERR:** Error signal (Photocoupler output)
It will be ON when abnormality occurs in the monitor.
- ZIN:** Zero calibration start pulse input
This is an external signal used only when you want to start zero calibration.
- AUX:** Auxiliary terminal
Normally, this is not used, so do not connect any wires.

6.4.2 Signal output connection

Signal outputs from the control unit are all insulated by the photocoupler (open collector). The corresponding signal output is below (4 types, 6 systems).

Determine the resistance value [R] so that $1 \leq i \leq 10$ mA. (See Figure-9)

- (1) Concentration alarm (AL1, AL2)
- (2) Pressure alarm (PA1, PA2)
- (3) Error signal (ERR)
- (4) Measurement signal (MES)

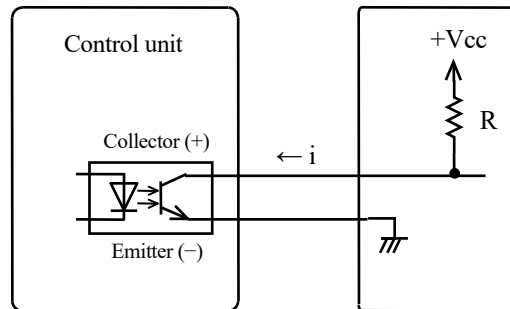

Figure-9 Recommended circuit

The current [i] applying through the monitor (photocoupler) is obtained from the following equation. Decide the value of [+Vcc] and [R] so that the current [i] will be 1 to 10 mA. However, it should be [+Vcc ≤ 50 V]. Be careful that the wrong polarity may cause in failure.

$$i = \frac{+V_{cc}}{R} \quad [\text{A}]$$

For example, in case that +Vcc equals 5 V and R is 1 kΩ, [i] comes to 5 mA.

An example of the circuit when using relays is shown in Figure-10. Please select parts used to satisfy various conditions.

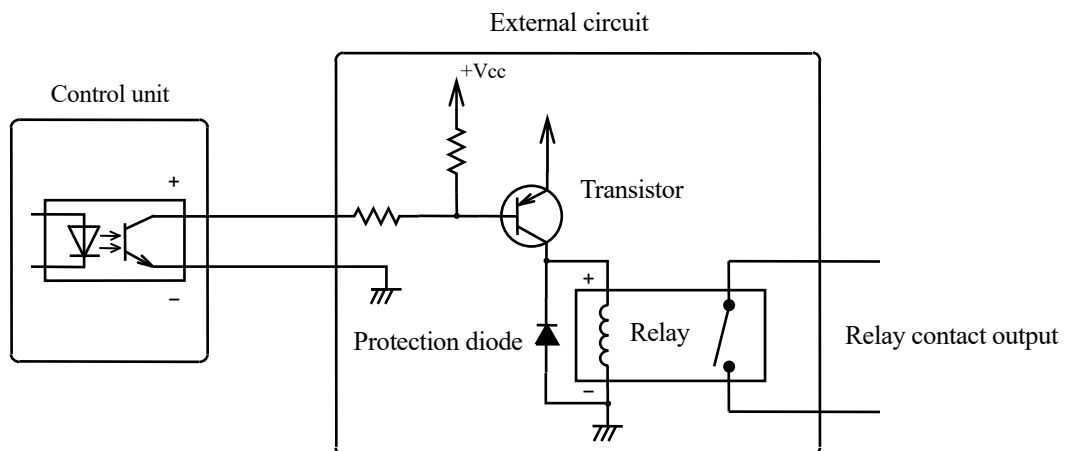

Figure-10 Example circuit of connection

6.4.3 Connecting input signal

The only input signal for this monitor is “zero calibration start pulse input (ZIN)”. For connection, zero calibration operates by applying the specified current to the LED side of the photocoupler. The input signal is isolated from the inside of the monitor.

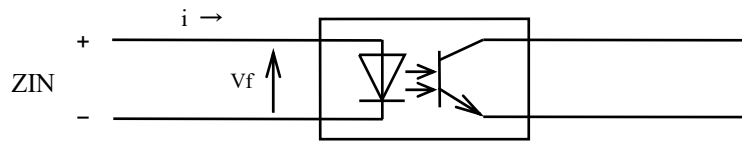

Figure-11 Internal circuit of input signal

Note

Limit the current [i] applied to the internal LED to 10 to 20 mA.

6.5 Control signal output of detector unit

There is no polarity with the contact output of the semiconductor relay. 100 V AC (DC is also available), 0.4 A (peak value) or less, a-contact. It is the output signal from the detector terminal block. Appropriate tightening torque is 0.5 N·m.

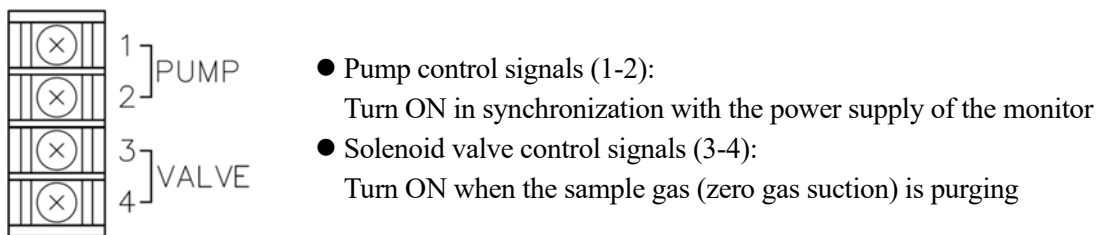

Figure-12 Detector unit terminal block

6.6 Connection between the control unit and the detector unit

Connect both the connectors attached on the control unit and the detector unit by using the supplied interface cable. Do not use cables exceeding 15m for maintaining performance. Furthermore, be sure to use genuine ones.

7. Span calibration

This monitor has been span calibrated before delivery and there is no need to recalibrate. You can change the span calibration ratio when correlating with your analysis value.

The span calibration ratio of the monitor can be set in increment of 0.1%.

After changing the span calibration ratio, when returning to the span calibration ratio at the time of shipment, check the serial number and refer to the span calibration ratio described in the ozone monitor test report.

8. Model code

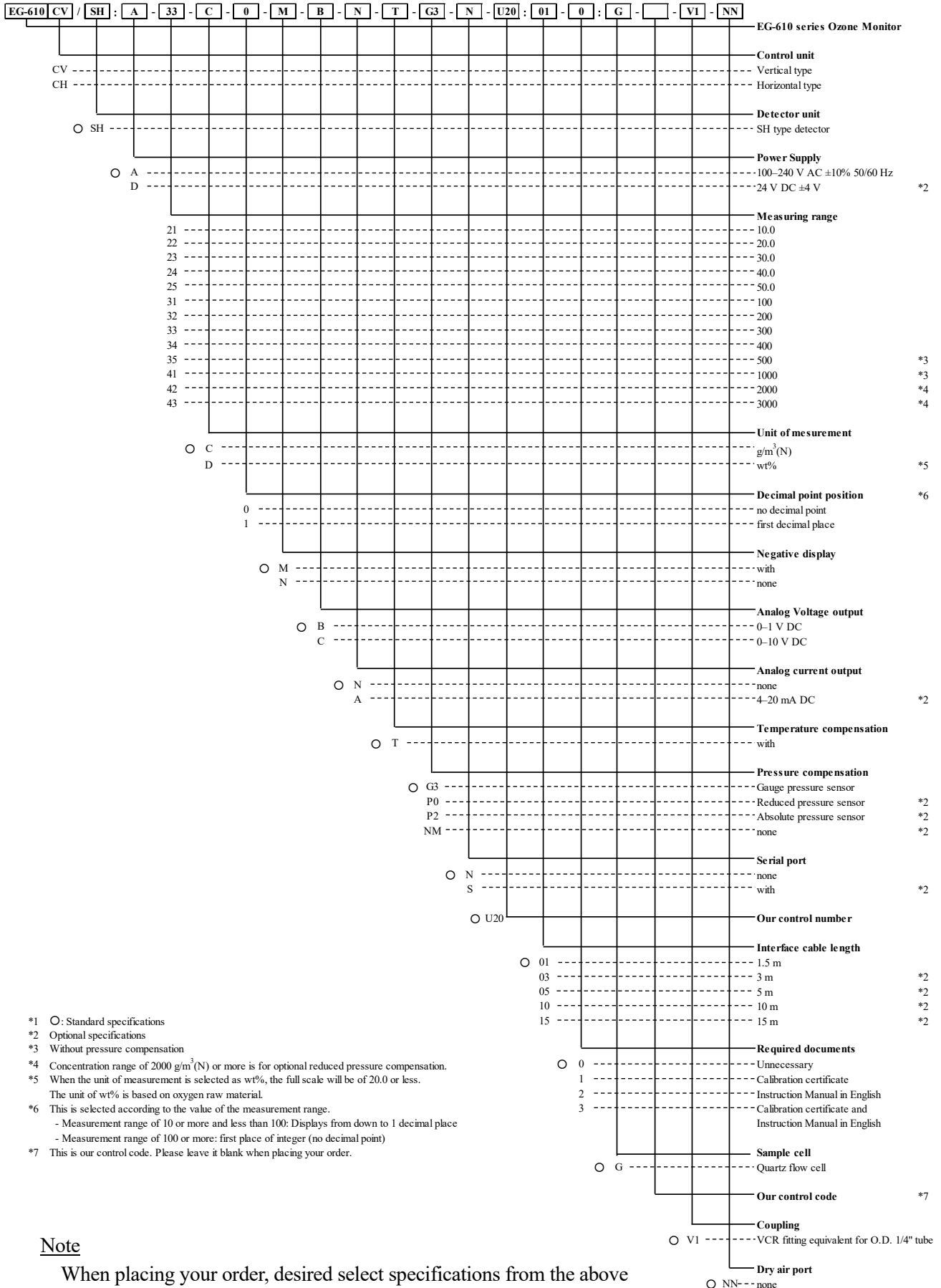

*1 O: Standard specifications
 *2 Optional specifications
 *3 Without pressure compensation
 *4 Concentration range of 2000 g/m³ (N) or more is for optional reduced pressure compensation.
 *5 When the unit of measurement is selected as wt%, the full scale will be of 20.0 or less.
 The unit of wt% is based on oxygen raw material.
 *6 This is selected according to the value of the measurement range.
 - Measurement range of 10 or more and less than 100: Displays from down to 1 decimal place
 - Measurement range of 100 or more: first place of integer (no decimal point)
 *7 This is our control code. Please leave it blank when placing your order.

Note

When placing your order, desired select specifications from the above model code.
 If there is no designation, standard selection “O” will become applicable.

9. Warranty

The monitor will be warranted for a period of 12 months from the date of delivery.

Note, however, that the following items are not covered by the warranty even within the warranty period:

◇ Following events that occur during the warranty period:

- (1) Failure due to improper handling
- (2) Failure caused by improper repair or modification using non-genuine parts
- (3) Failure and damage due to fall after delivery or during transportation
- (4) Failure and damage caused by fire, salt damage, gas damage, earthquake, wind and flood damage, lightning, abnormal voltage, and other force majeure
- (5) Failure due to deterioration of consumable parts (such as packing and sealing materials)

This product only is covered by the warranty during the warranty period. We are not responsible for compensating any damage caused by its use (such as lost earnings, personal injury, and damage to other equipment).

◇ Others

- (1) Contact your dealer when repair is needed.
- (2) Repair should be done by the manufacturer side, so please return the product.
- (3) The minimum retaining period of performance components for repair of this product is 7 years after the discontinuance of production.
Note: The performance parts for repair are defined as parts necessary to maintain the intended performance of products.
- (4) The scope of warranty for failures due to unprecedented causes will be determined by discussion on a case-by-case basis.

Note that this specification is subject to change without prior notice due to improvement.

10. Export of our products

Our products (Goods or technology) are subject to catch-all regulations “Appended Table 1 (Item 16) of Export Trade Control Order and Appended Table (Item 16) of Foreign Exchange Order”.

Therefore, even if this product not subject to list regulations, it must be examined in accordance with the provisions of the “Foreign Exchange and Foreign Trade Act” for export or transfer overseas, and if permission is required, obtain permission from the Minister of Economy, Trade and Industry.

The country of origin of this product is Japan.

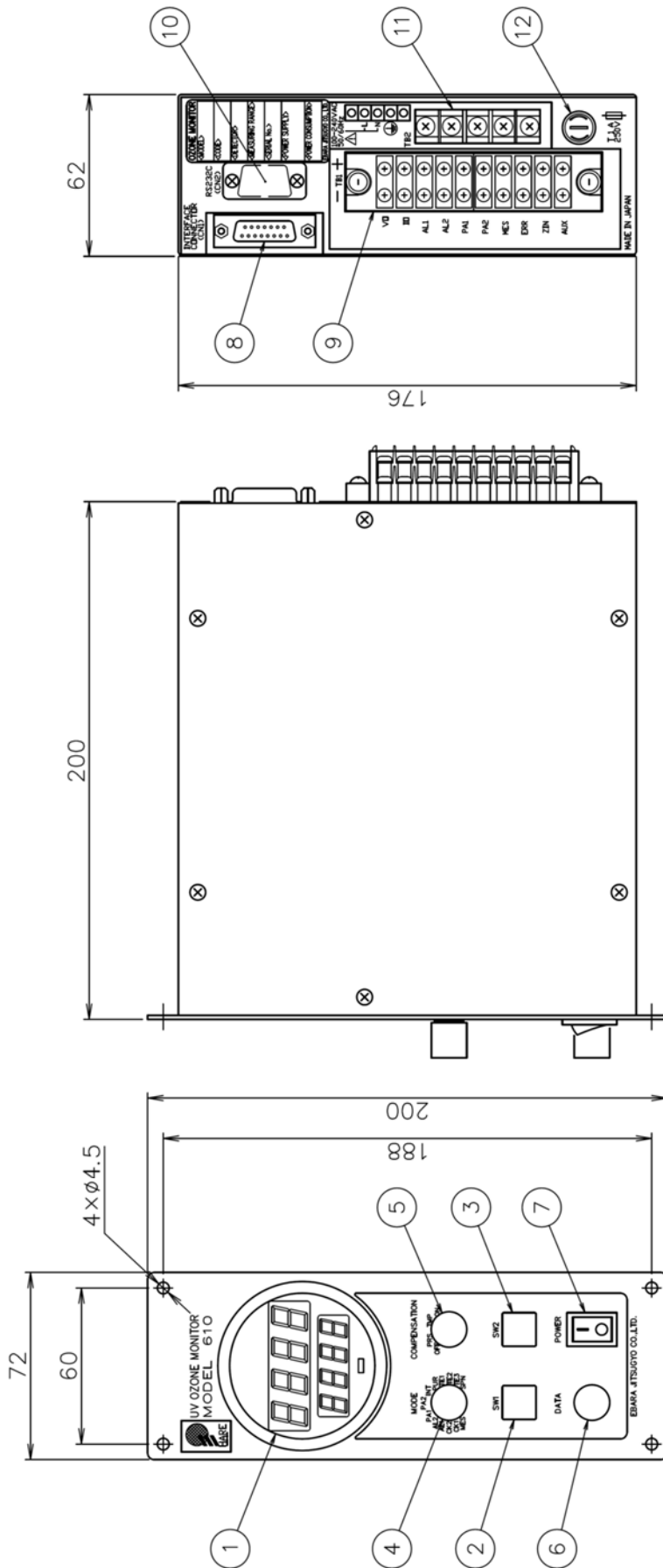

Attached drawing (1): Outline drawing of the vertical type control unit (EG-610CV)

Installation on the Panel
Cut out: 66 W × 180 H
Thickness: 2-5 mm

No.	Parts name	No.	Parts name
①	Display unit	⑦	Power switch
②	Setting switch 1 (SW1)	⑧	Detector interface connector (CNI)
③	Setting switch 2 (SW2)	⑨	Signal terminal block (TB1)
④	MODE switch (MODE)	⑩	RS232C connector (CN2) (optional)
⑤	COMPENSATION switch (COMPENSATION)	⑪	Power supply terminal block (TB2)
⑥	Data input dial (DATA)	⑫	Fuse holder (FUSE)

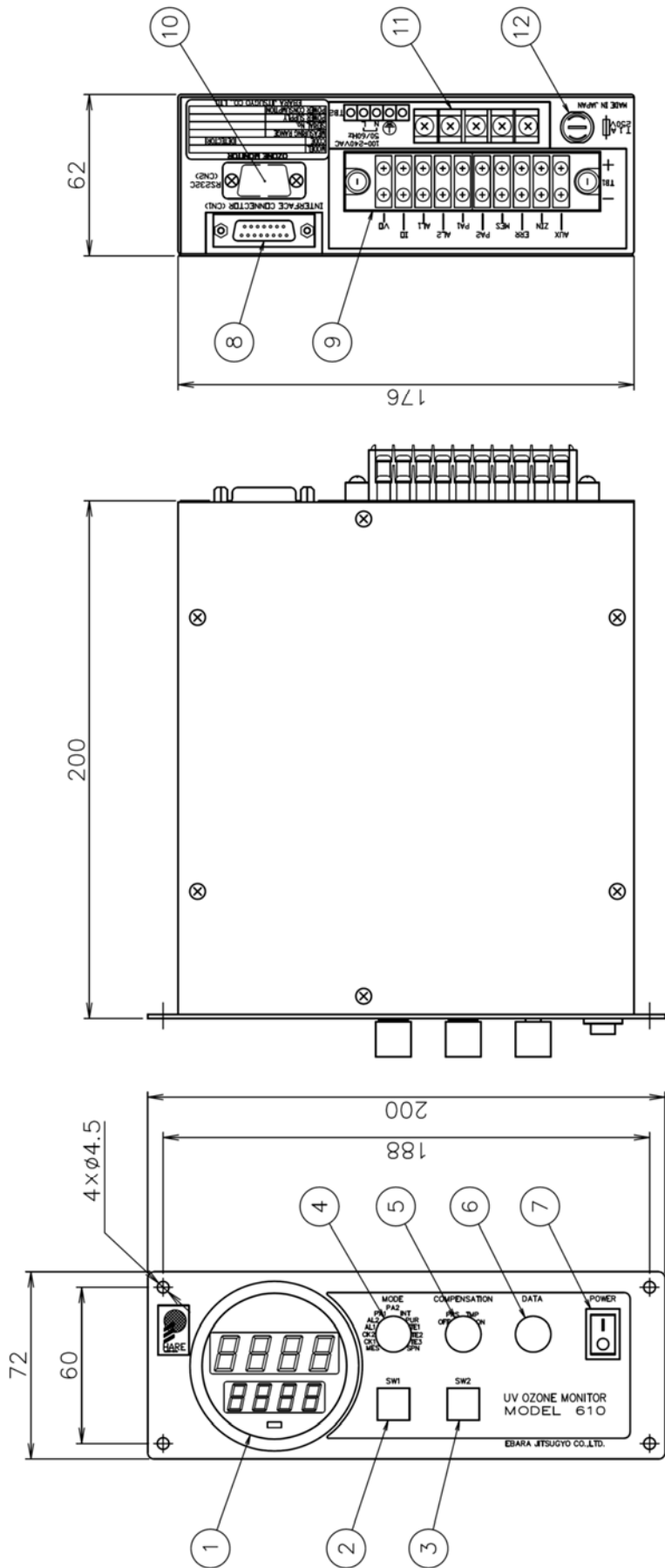

Installation on the Panel
Cut out: 66 W × 180 H
Thickness: 2-5 mm

No.	Parts name	No.	Parts name
①	Display unit	⑦	Power switch
②	Setting switch 1 (SW1)	⑧	Detector interface connector (CNI)
③	Setting switch 2 (SW2)	⑨	Signal terminal block (TB1)
④	MODE switch (MODE)	⑩	RS232C connector (CN2) (optional)
⑤	COMPENSATION switch (COMPENSATION)	⑪	Power supply terminal block (TB2)
⑥	Data input dial (DATA)	⑫	Fuse holder (FUSE)

Attached drawing (2): Outline drawing of the horizontal type control unit (EG-610CH)

荏原実業株式会社

EBARA JITSUGYO CO., LTD.

計測器・医療本部

MEASURING INSTRUMENT AND MEDICAL DIVISION

計測器営業部

MEASURING INSTRUMENT SALES DEPARTMENT

東日本営業グループ
EAST JAPAN SALES GROUP

〒215-0033
神奈川県川崎市麻生区栗木 2-3-12
2-3-12 Kuriqi, Asao-ku, Kawasaki-shi, Kanagawa, 215-0033 JAPAN
TEL: 044-981-0560 FAX: 044-981-0561
+81-44-981-0560 +81-44-981-0561
E-mail: ej-ozone@ejk.co.jp

西日本営業グループ
WEST JAPAN SALES GROUP

〒541-0046
大阪府中央区平野町 3-2-13 平野町中央ビル 5 階
3-2-13, Hiranocho, Chuo-ku, Osaka-shi, Osaka, 541-0046 JAPAN
TEL: 06-6231-3528 FAX: 06-6231-2929
+81-6-6231-3528 +81-6-6231-2929
E-mail: ozon-osaka@ejk.co.jp